



8PT25 Spring/Non-Spring-Loaded Thermocouple with Connection Head For Frame 6, 7 and 9 Gas Turbine Applications

AMETEK Power Instruments Spring /Non-Spring-Loaded Thermocouple probes meet the required operational and performance requirements for OEM and replacement Frame gas turbine applications. Power Instruments' expertise in solving creep, stress rupture, corrosion, EMF drift and other problems affecting sensor performance has resulted in a robust line of single and dual element thermocouple designs. This thermocouple is immersed directly into the turbine fluid to monitor temperature while in operation.

Power Instruments Thermocouples use 20 AWG stranded teflon insulated wire that is an ungrounded Class 2 thermocouple. The ½" MNPT threaded fitting allows for easier installation and maintenance for new installs, retrofits or upgrades to any Frame Gas Turbine engine. The seamless 316SS grade sheath material provides protection against all types of elements that could cause the sensor to fail during operation.

Each thermocouple is rated for operation ranges -20°C to 200°C. Design properties are type K configuration with MgO insulation and seamless stainless-steel sheathing. The thermocouple probe tips and terminations are hermetically sealed against exposure to operational environments and have been qualified to ASTM E585 and ASTM E608 standards with a leak rate of less than 1x10⁻⁶ cc/sec.

For detailed descriptions and drawings for the 8PT25 series thermocouples, please contact us.

FEATURES AND BENEFITS

1	Connection heads are ATEX certified and/or CSA/CE approved
2	Variety of OEM qualified connection head styles for normal and high temperature applications
3	Available in cast iron or aluminum style connection head configuration
4	Threaded fitting allows for quick installation/removal of thermocouple
5	Designed life expectancy of 450 cycles (24,000 operating hours)
6	Withstand environmental conditions like dirt, sand, soot, gases and other moistures

SPECIFICATIONS

VIBRATION/CALIBRATION

- Sweep range 20 – 600 Hz
- Calibration tolerance of $\pm 1.1^{\circ}\text{C}$ or .4%

MOISTURE SEAL

- Helium leak rate max of 6×10 cc/sec

TEMPERATURE AT ENVIRONMENTAL SEAL

- -20°C to 204°C (-28.9°F to 400°F)

LENGTHS

- Various from 2" to 24"
- Seamless 316SS sheath material



Cast Iron Connection Head Configuration

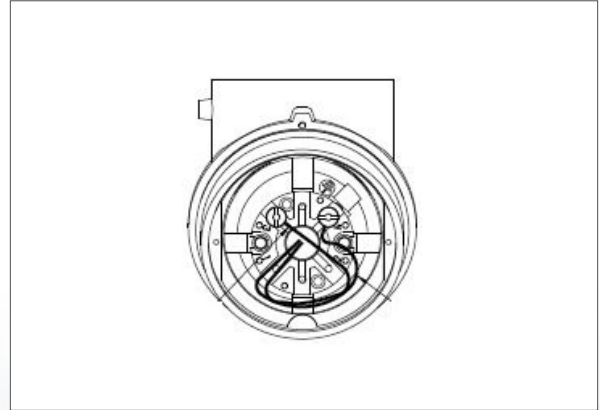

Aluminum Connection Head Configuration

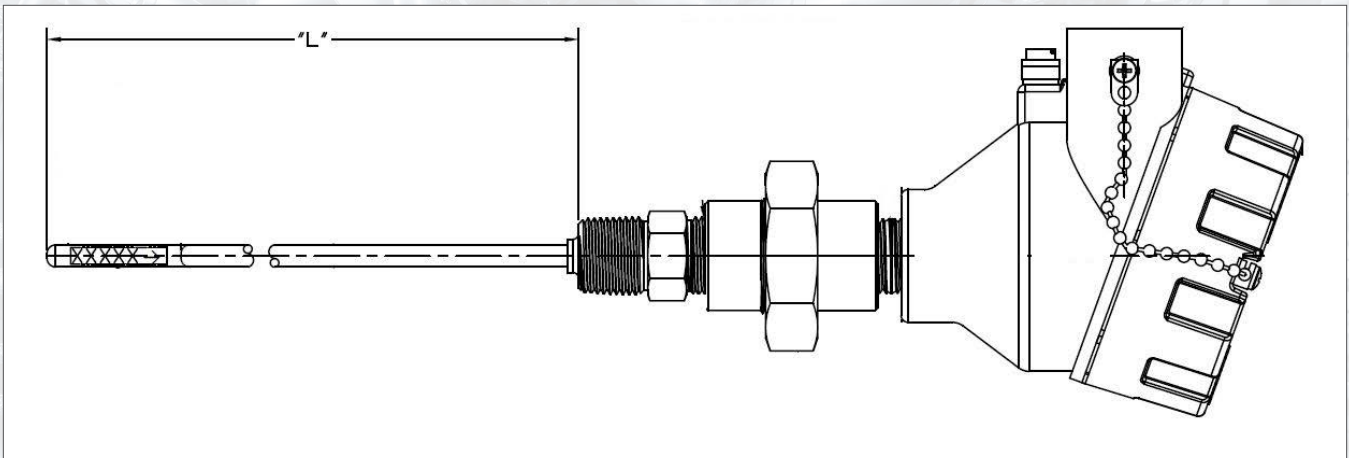

8PT25 with Aluminum Connection Head

AMETEK Power Instruments also manufactures a full line of sensors for gas and steam turbine applications. These include flame sensors, RTDs, thermocouples, cables and radiation shields. We manufacture to OEM requirements and can design and test to meet your unique application requirements. For more information, please visit our website at www.ametekpower.com or contact us directly at pi.marketing@ametek.com.

WORLD HEADQUARTERS

255 North Union Street
Rochester, NY 14605
Toll Free: +1.800.950.6686
Tel: +585.263.7700
Fax: +585.454.7805

EUROPEAN HEADQUARTERS

UK
+44.770.280.9377
power.sales@ametek.com

ASIA PACIFIC HEADQUARTERS

Singapore
+65.6484.2388
sales@ametekasia.com

AMETEK INSTRUMENTS INDIA PVT. LTD.

Bengaluru
+91.80.6782.3252
power.sales@ametek.com

WEBSITE

www.ametekpower.com

EMAIL

power.sales@ametek.com

AMETEK®

POWER INSTRUMENTS

REV 04/2026

